

Absolute encoders - bus interfaces

Blind hollow shaft up to $\varnothing 14$ mm

Optical multiturn encoders 13 bit ST / 12 bit MT, RS485

GXM7S - RS485



GXM7S with blind hollow shaft

Features

- Encoder multiturn / RS485
- Optical sensing method
- Resolution: singleturn 13 bit, multiturn 12 bit
- Blind hollow shaft $\varnothing 12$ mm / $\varnothing 14$ mm
- Fieldbus protocol
- Up to 4 bus users
- Bus access according to master/slave principle
- Maximum resistant against magnetic fields

Optional

- Integration of customer-specific RS485 protocols

Technical data - electrical ratings

Voltage supply	10...30 VDC
Reverse polarity protection	Yes
Consumption w/o load	≤ 50 mA (24 VDC)
Initializing time typ.	250 ms after power on
Interface	RS485
Function	Multiturn
Transmission rate	38.4 kBaud
Device adress	Coded by connection
Steps per turn	8192 / 13 bit
Number of turns	4096 / 12 bit
Absolute accuracy	$\pm 0.025^\circ$
Sensing method	Optical
Code	Binary
Code sequence	CW/CCW coded by connection
Output stages	RS485
Interference immunity	DIN EN 61000-6-2
Emitted interference	DIN EN 61000-6-4
Approval	UL approval / E63076

Technical data - mechanical design

Size (flange)	$\varnothing 58$ mm
Shaft type	$\varnothing 12$ mm (blind hollow shaft) $\varnothing 14$ mm (blind hollow shaft)
Protection DIN EN 60529	IP 54
Operating speed	≤ 6000 rpm (mechanical) ≤ 6000 rpm (electric)
Starting acceleration	≤ 1000 U/s ²
Starting torque	≤ 0.015 Nm (+25 °C, IP 54)
Rotor moment of inertia	20 gcm ²
Materials	Housing: steel Flange: aluminium
Operating temperature	-25...+85 °C -40...+85 °C (optional)
Relative humidity	95 % non-condensing
Resistance	DIN EN 60068-2-6 Vibration 10 g, 16-2000 Hz DIN EN 60068-2-27 Shock 100 g, 6 ms
Weight approx.	400 g
Connection	Connector M23, 12-pin Cable 1 m

Absolute encoders - bus interfaces

Blind hollow shaft up to $\varnothing 14$ mm

Optical multiturn encoders 13 bit ST / 12 bit MT, RS485

GXM7S - RS485

Part number

GXM7S.		10		01
				Interface
			01	RS485
				Connection
		A1		Connector M23, 12-pin, radial
		21		Cable 1 m, radial
				Blind hollow shaft
0				$\varnothing 12$ mm, without pin
1				$\varnothing 12$ mm, pin 15 mm
B				$\varnothing 12$ mm, pin 9.5 mm
4				$\varnothing 14$ mm, without pin
5				$\varnothing 14$ mm, pin 15 mm
F				$\varnothing 14$ mm, pin 9.5 mm

Accessories

Connectors and cables

Z 130.001	Female connector M23, 12-pin, without cable
Z 130.003	Female connector M23, 12-pin, 2 m cable
Z 130.005	Female connector M23, 12-pin, 5 m cable
Z 130.007	Female connector M23, 12-pin, 10 m cable

Mounting accessories

Z 119.024	Torque support and spring washer for encoders with 9.5 mm pin
Z 119.041	Torque support by rubber buffer for encoders with 15 mm pin
Z 119.050	Spring coupling for one-side attachment, length 35 mm
Z 119.053	Spring coupling for motor's fan guard
Z 119.072	Spring coupling for encoders with $\varnothing 58$ mm housing, hole distance 73 mm
Z 119.073	Spring coupling for encoders with $\varnothing 58$ mm housing, hole distance 68 mm
Z 119.076	Spring coupling for one-side attachment, length 115 mm
Z 119.082	Spring coupling for encoders with $\varnothing 58$ mm housing, hole distance 63 mm

Data transmission format

Basic settings of RS485 serial interface

- 1 start bit
- 8 data bits (least significant bit first)
- 1 stop bit
- Parity none
- Baud rate: 38.4 kBaud

Structur of data fields

Demand from master

SOH	80h	ADR	80h	EOT
-----	-----	-----	-----	-----

Reply of encoder

SOH	EAD	MT_H	MT_L	ST_H	ST_L	LRC	EOT
-----	-----	------	------	------	------	-----	-----

Explanation

SOH	Value = 01h
ADR	Address of encoder, value 02h - 05h
EOT	Value = 04h
EAD	Bit 0 - 3 response of encoder address (bit 4 -7 not defined)
MT_H	High byte revolution
MT_L	Low byte revolution
ST_H	High byte steps
ST_L	Low byte steps
LRC	EAD XOR MT_H XOR M_T_L XOR ST_H XOR ST_L

Absolute encoders - bus interfaces

Blind hollow shaft up to $\varnothing 14$ mm

Optical multiturn encoders 13 bit ST / 12 bit MT, RS485

GXM7S - RS485

Terminal significance	
UB	Encoder voltage supply.
GND	Encoder ground connection relating to UB.
T,R IN T,R OUT	Serial data lines. To avoid stub lines the data lines are guided outside on a pair of 2 wires. The arriving bus is on T,R+ IN and T,R- IN, the departing bus on T,R+ OUT und T,R-. If the encoder serves as bus termination or is the only user, only the pair of wires T,R+ IN and T,R- IN is utilized. Note: External connection of terminating resistor 150 Ω to final user.
Zero setting	Input for setting a zero point anywhere within the programmed encoder resolution. The zero setting operation is triggered by a High impulse and has to be in line with the selected direction of rotation (UP/DOWN). Connect to GND after setting operation for maximum interference immunity. Impulse duration ≥ 100 ms.
UP/DOWN	UP/DOWN counting direction input. This input is standard on High. UP/DOWN means ascending output data with clockwise shaft rotation when looking at flange. UP/DOWN-Low means ascending values with counterclockwise shaft rotation.
Ident 1...2	Ident 1...2 are utilized for setting the encoder addresses (identifiers). Less potential the inputs are internally against UB (=“1”) by pull-up resistors what equals address 2.

Address	2	3	4	5
Ident 1	1	0	1	0
Ident 2	1	1	0	0

Terminal assignment		
Connector	Core colour	Assignment
Pin 1	brown	UB
Pin 2	black	GND
Pin 3	blue	T,R+ IN
Pin 4	beige	Ident 1
Pin 5	green	T,R- OUT
Pin 6	yellow	Ident 2
Pin 7	violet	T,R- IN
Pin 8	brown/yellow	UP/DOWN
Pin 9	pink	T,R+ OUT
Pin 10	black/yellow	Zero setting
Pin 11	–	–
Pin 12	–	–

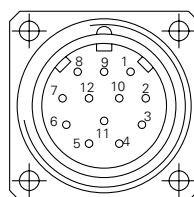

Please use cores twisted in pairs (for example T,R+ / T,R-) for extension cables of more than 10 m length.

Trigger level	
Interface	Circuit
Data	Linedriver RS485

Control inputs	Input circuit
Input level High	>0.7 UB
Input level Low	<0.3 UB
Input resistance	10 k Ω

Absolute encoders - bus interfaces

Blind hollow shaft up to $\varnothing 14$ mm

Optical multiturn encoders 13 bit ST / 12 bit MT, RS485

GXM7S - RS485

Dimensions

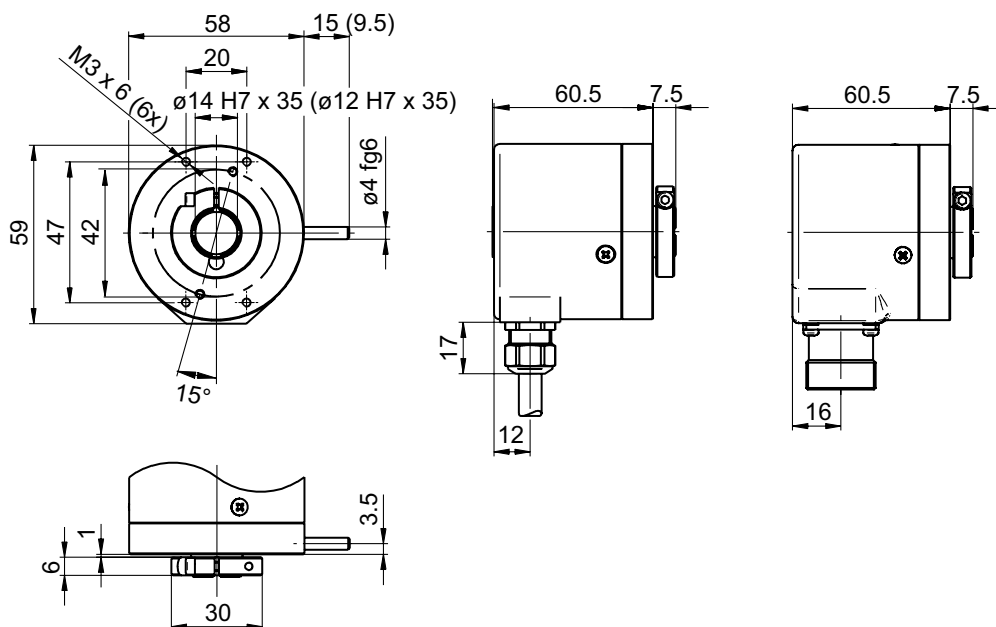

GXM7S - connector dimensions

